

Where to Apply Waxoyl / Rust Proofing

Lindsey Porter's "Improve and Modify the MGB" (worth buying) has a few pages on rustproofing. Here's what he suggests spraying:

1. Underneath the chrome trim strip below the rear windows on GT's
2. The 'ledge' inside the front wings which can be accessed from inside the engine bay
3. The tailgate doors on GTs and the boot lid on the roadster -- spray inside the small box sections
4. Inside the doors (remove the doors cards, obviously). Clear the drain channels if not open.
5. Beneath the quarter lights inside each door (water enters through dried gaskets)
6. Inside the front box section of the bonnet (there are holes)
7. Clean first, then spray the front inside of the fenders (I also spray the back of my chrome bumpers since they get rusty back there)
8. Remove the vertical mud trap panel from behind the front wheels, and spray there -- or drill holes into the vertical panel (plug them later) to do this.
9. Drill holes in sills below doors and rustproof the box sections (as I mentioned above) -- and remember there are two parallel box sections
10. Where the rear inner wing joins the rear outer wing is a rust area. Spray from inside the trunk (remove any trim from inside the trunk to access this)
11. Main chassis rails -- there's a hole at the rear giving some access
12. Center chassis rails through holes available
13. Through holes in the smaller 'castle' sections alongside the frame rails -- there are pre-existing holes
14. Inside the cross member which joins the two rails
15. The support for the rear spring-shackle where it fits against the body at its forward end has a rust-prone seam which should be soaked with rustproof
16. Jacking points

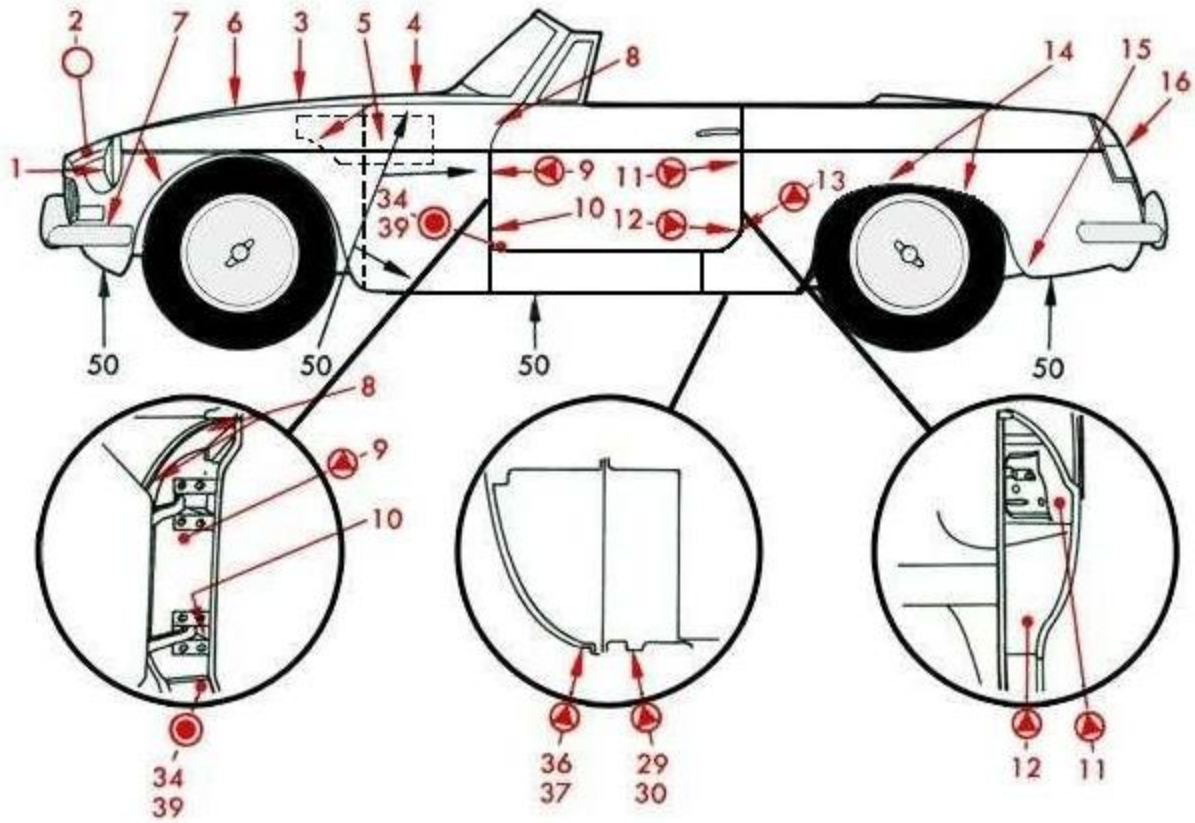

EXISTING HOLES



HOLES TO BE DRILLED



EXISTING HOLES TO BE PLUGGED



HOLES TO BE DRILLED AND PLUGGED

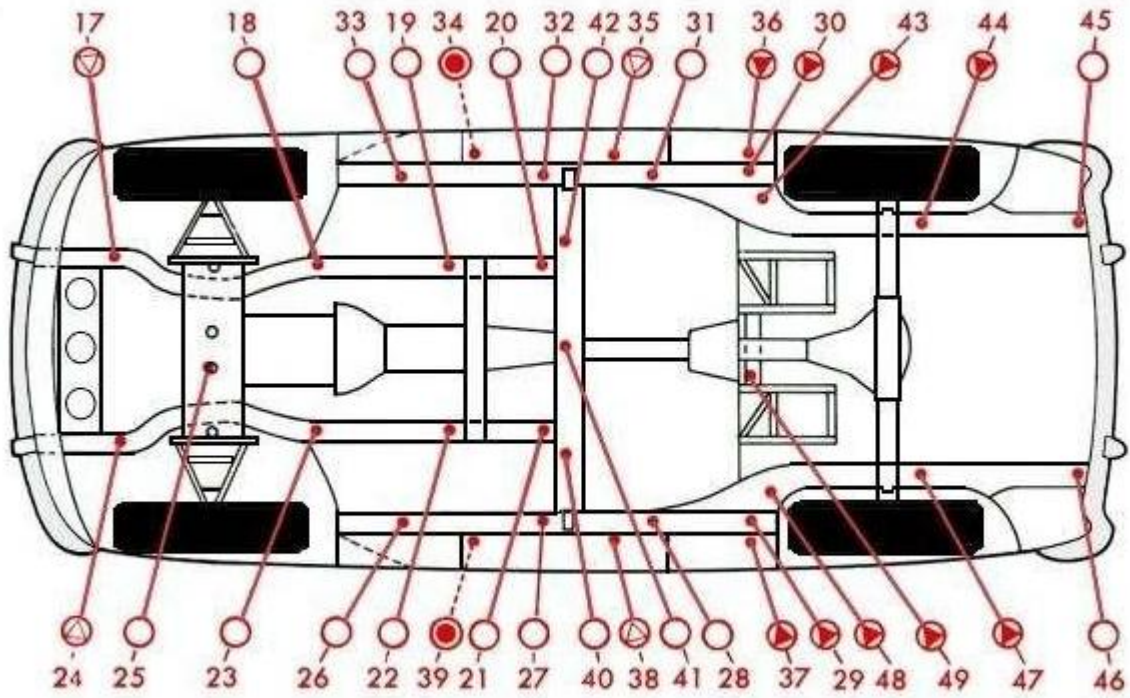

○ EXISTING HOLES

△ HOLES TO BE DRILLED

● EXISTING HOLES TO BE PLUGGED

▲ HOLES TO BE DRILLED AND PLUGGED